

# delight

by Sebastian Herkner  
TABLES



Produced from handblown glass, their unique form is reminiscent of a pair of candy cubes sweetly fused into one. Inviting curves highlighted by a textured and frosted exterior that keeps you coming back for one more bite.

**YEAR OF DESIGN**  
2018

**MATERIAL**  
handblown glass

**DIMENSIONS** (mm)  
SMALL  
Ø 360 × 380 H  
BIG  
Ø 460 × 500 H

**COLOURS + ART. NR**



	aubergine	smoky grey	tarpaulin
SMALL	9300AUB	9300G	9300T
BIG	9301AUB	9301G	9301T

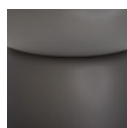
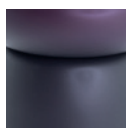

	aubergine acetato	smoky grey acetato	tarpaulin acetato
SMALL	9300AUBAC	9300GAC	9300TAC
BIG	9301AUBAC	9301GAC	9301TAC

**PROCESS**  
Each piece is created from handblown glass, coloured and/or sanded. Bubbles, streaks and other variations in size and colour are part of handmade production processes, and not defects in the design or production.

### delight small

Ø 360 × 380 H

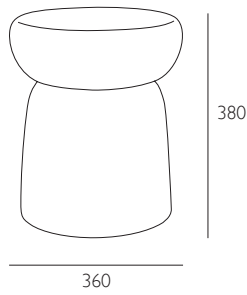

### delight big

Ø 460 × 500 H

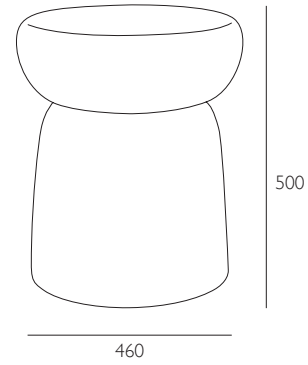

---

#### CARE INSTRUCTIONS

Regular cleaning and maintenance is important in order to keep your pulpo product looking its best and to prolong its life. Always remove any kind of dirt as soon as possible. We recommend that you first test a small, invisible area to ensure that no colour change or damage arises to the product. Do not use materials for maintenance that contain abrasive agents or are basic, acid or organic.

#### GLASS CLEANING

For dusting and light cleaning of glass use a soft, dry cloth. For further cleaning gently wipe the surface with a soft cloth wrung in clean water and a non-abrasive commercial glass cleaner. Dry immediately afterwards with a soft, dry and clean cloth. Please note that bubbles, streaks and other variations in size and colour are part of the production process, and not defects of the design or production of handmade glass.