

cut

by Studio BrichetZiegler
CHAIR & OTTOMAN



Combining a structural rigidity with a freedom in finish, the cut lounge chair presents a case of subtle intrigue. A simple steel frame is covered with an oversized piece of leather, the excess of which converges where seat and back meet. The result is a chair that brings together the industrial and the handmade.

YEAR OF DESIGN
2018

MATERIAL
leather; powder coated steel

DIMENSIONS (mm)
CHAIR
600 L x 565 W x 735 H
OTTOMAN
600 L x 470 W x 450 H

COLOURS + ART. NR



SEAT LEATHER	black	green
FRAME STEEL	black	green
CHAIR	1500B	1500GR
OTTOMAN	1501B	1501GR

PROCESS
The legs and frame are constructed from powder coated steel. A single piece of tanned leather is then glued to the metal frame. Marks and folds in the leather are part of the production process, and not defects of the design or production.

cut chair

600 L x 565 W x 735 H

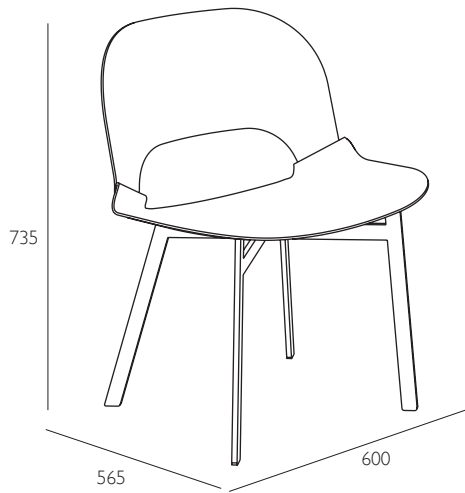

cut ottoman

600 L x 470 W x 450 H

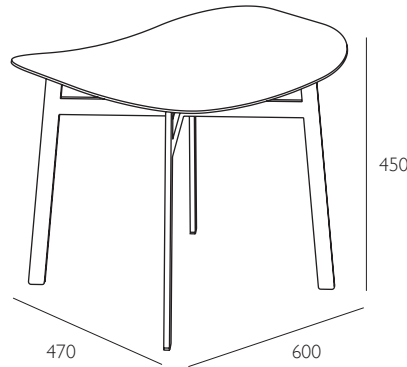

CARE INSTRUCTIONS

Regular cleaning and maintenance is important in order to keep your pulpo product looking its best and to prolong its life. Always remove any kind of dirt as soon as possible. We recommend that you first test a small, invisible area to ensure that no colour change or damage arises to the product. Do not use materials for maintenance that contain abrasive agents or are basic, acid or organic.

METAL CLEANING

STEEL POWDER COATED

For dusting and light cleaning of the base, use a soft and dry cloth. For further cleaning, gently wipe the surface with a soft cloth wrung in clean water and a neutral detergent or soap flakes of good quality. Dry immediately afterwards with a soft, dry and clean cloth. For the best maintenance of the product, care for it regularly, protect it against direct sunlight and heat, and try to keep it away from moisture, grease, and other dirt. Furthermore, protect the surfaces against sharp objects and other that might scratch.

NAPPA LEATHER

For dusting and light cleaning of Nappa leather first try to gently brush off any dirt. If required vacuum the surface with a soft brush. For further cleaning, mix clean boiled water and a neutral soap to create a foam. Using a wrung soft cloth, gently rub the foam into the leather using a circular motion. Dry immediately afterwards with a soft, dry and clean cloth.