

pilota

by Studio BrichetZiegler
CHAIR



GENEROUS. BOLD. EVOCATING.

Starting from a simple construction, ending in a seat with refined but strong lines. This low chair offers a comfortable and very sculptural seat. It is composed of two rolled, painted sheet metal shells, whose empty body is covered by the seat and the backrest. Despite the simplicity of the structure, the generous shapes create a bold and impressive design.

YEAR OF DESIGN

2021

MATERIAL

Rolled lacquered steel, plywood and upholstery, leather or textile leather, cord, faux fur, wool

DIMENSIONS (mm)

650 L X 750 W X 750 H

PRODUCT CHARACTERISTICS

The pilota is a masterwork of traditional craftsmanship. Each chair is handmade and has characteristic features such as irregularities in metal base or fabric top and colour variations.

ASSEMBLY REQUIRED

No.

COLORS + ART. NR

fabric	cord brown	black leather	black leather	black leather
frame	pearl beige	fango green	smoky grey	silver
	7800BCPB	7800BLFG	7800BLSG	7800BLSI
fabric	grey faux fur	rose wool	terracotta leather	
frame	white aluminium	beige red	white green	
	7800GRWA	7800ROBR	7800TERWG	

pilota

650 L × 750 W × 750 H

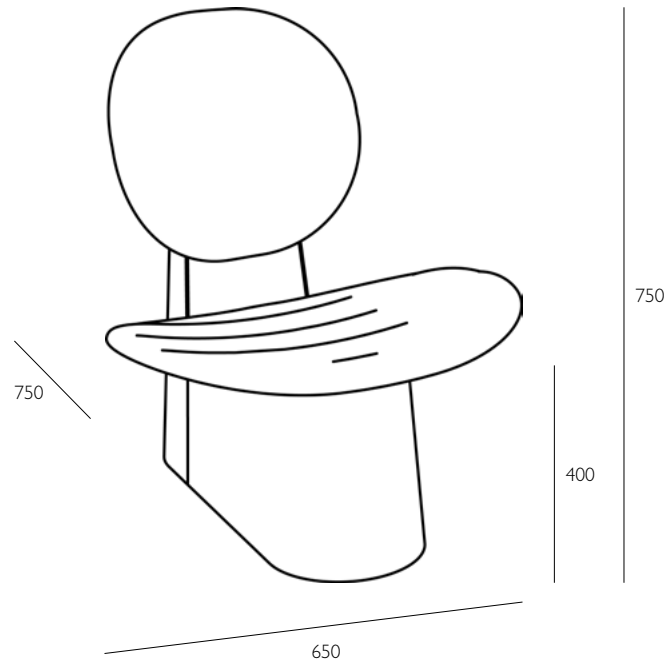

CARE INSTRUCTIONS

Regular cleaning and maintenance is important in order to keep your pulpo product looking its best and to prolong its life. Always remove any kind of dirt as soon as possible. We recommend that you first test a small, invisible area to ensure that no colour change or damage arises to the product. Do not use materials for maintenance that contain abrasive agents or are basic, acid or organic.

LEATHER CLEANING

If necessary, vacuum the leather furniture with a soft brush. Remove small stains with a damp cloth and wipe dry. Never use stain removers, shoe polish, solvents, floor wax or other inappropriate products. Premium leather is more sensitive due to the natural tanning and should be vacuumed with a soft brush only. Never use stain removers, shoe polish, solvents, floor wax or other inappropriate products.

ALUMINIUM CLEANING

These finishes are relatively fine and should therefore be lightly cleaned with the utmost care, avoiding abrasive cleaning agents. Vigorous rubbing should be avoided.

Mild soap with water and a soft brush (like nylon bristles that are very soft, or natural brushes with soft texture) or a clean lint free soft cloth to clean. A freshwater rinse is recommended method of washing the aluminium furniture, and drying with a towel (as necessary.)

Regular wiping with a soft cloth will reduce the necessity for more stringent and possibly harmful action, if dirt and grease deposits are allowed to collect on the surface.

FAUX FUR CLEANING

Brush the faux fur gently with a soft brush to remove loose dirt and grime particles. Try not to tangle the fur as you brush it. Dampen a terry cloth with water. Wring out the excess water from the cloth so that it is only slightly moist.

UPHOLSTERY/WOOL CLEANING

Vacuum upholstery regularly using the appropriate attachment. Many spots can be removed with a cloth and warm water, with the addition of a mild soap if necessary. If you need to use stain remover, first test it in a hidden spot. Do not use any cleaners that contain bleach, and avoid strong rubbing. Care-fully dry damp areas with a hairdryer in order to counteract water stains. In case of heavy soiling or difficult stains, consult a professional. Removable covers should be professionally cleaned only.

VELVET CORD CLEANING

Velvet corduroy makes a plush, durable upholstery with a soft, luxurious feel. It is often treated with a stain guard product for easy care. When considering how to care for your upholstery, avoid excessive heat that can shrink the fabric. Use products designed for upholstery cleaning to avoid water spots and dry the upholstery quickly. Vacuum your upholstery weekly and blot up any spills to maintain its appearance.